

# TO-252

**Plastic, surface-mounted package; 3 terminals;  
2.286 mm pitch; 6.1 mm x 6.6 mm x 2.3 mm body**  
塑料表面贴装封装；3 引脚；间距 2.286 mm；  
封装本体尺寸 6.1 mm x 6.6 mm x 2.3 mm

## 1. Mechanical Data 封装数据

Feature 特性	Description 描述
Package 封装	TO-252
Moisture Sensitivity Level 湿敏感度等级	J-STD-020 MSL1
Mounting Method Type 安装方式类型	Surface Mount Package 表面贴装封装
Material 材料	Molded Plastic, “Green” Molding Compound; UL Flammability Classification Rating 94V-0. 模塑塑料封装，“绿色”成型复合材料；UL 可燃性等级 94V-0。
Dimensions 尺寸	2.286mm pitch; 6.1mm × 6.6mm × 2.3mm body 相邻引脚中心距为 2.286mm，封装本体(不含引脚)尺寸为 6.1mm × 6.6mm × 2.3mm
Terminals Compliance 引脚合规	3 terminals, Tin Plated Leads; exposed die pad for good heat transfer; Solderable per MILSTD-202, Method 208 <sup>e3</sup> 3 个镀锡引脚，外露散热焊盘以增强热传导；可焊性符合 MIL-STD-202 标准中 208 方法 e3 条款的要求
Weight 重量	2.24 grams (Approximate) 约 2.24 克

## 2. Package Outline Dimensions 封装外形尺寸

TO-252

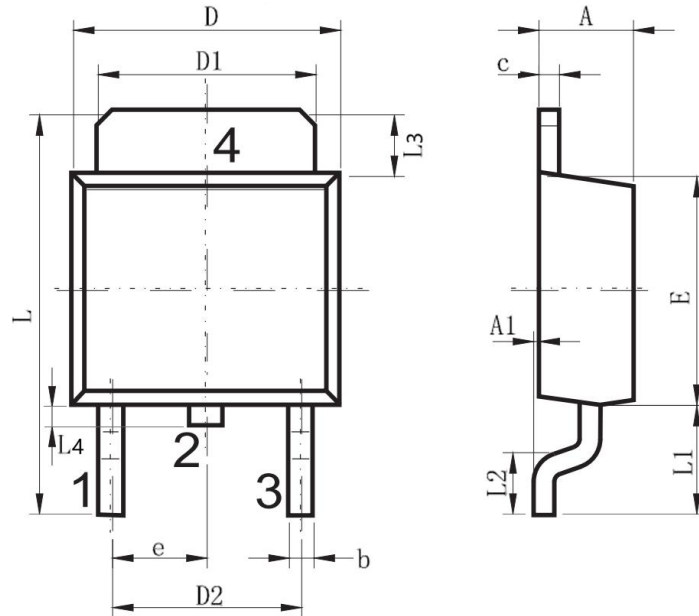

Symbol 符号	Millimeters 毫米	
	Min.最小值	Max.最大值
A	2.10	2.50
A1	-	0.127
b	0.50	0.90
c	0.30	0.70
D	6.30	6.70
D1	5.10	5.50
D2	4.4	4.8
E	5.50	6.30
e	2.10	2.50
L	9.70	10.10
L1	2.70	3.10
L2	1.40	1.78
L3	1.20	1.60
L4	-	1.01

### 3. Suggested Pad Layout 推荐焊盘布局

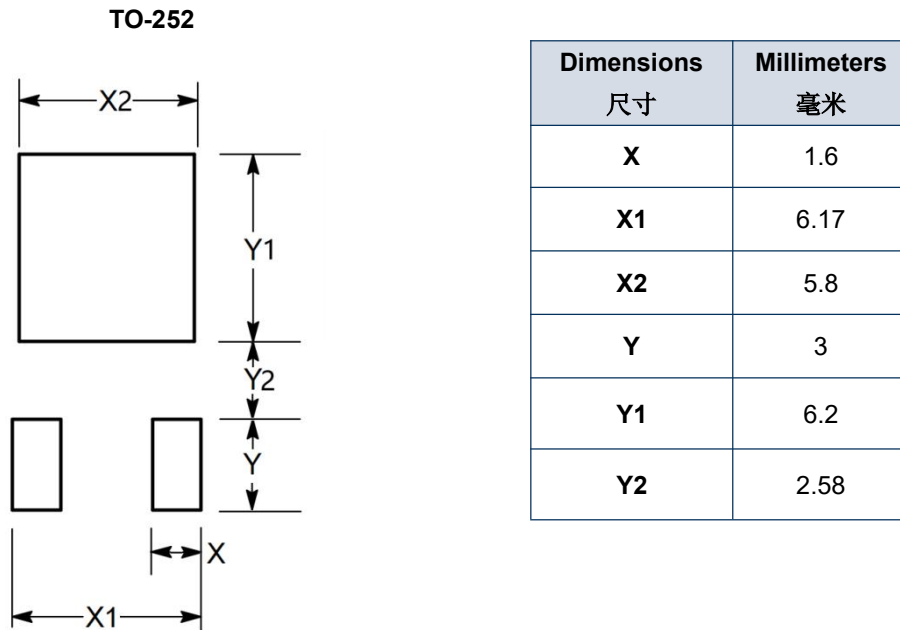

Fig. Soldering footprint for TO-252

图 TO-252 的引脚焊接

### 4. Minimum Packing Quantity 最小包装数量

Reel Size (inches)	Tape Width (mm)	Quantity Per Reel
13	16	2500

**Note:**

Package quantities given are for minimum packaging quantity only, not minimum order quantity. For minimum order quantity, please contact Sales Department.

**说明:** 上表所列包装数量仅为最低包装数量，并非最低订购数量。如需最低订购数量，请联系销售部门。



### Important Notice 重要通知

Jingpeng Hulian( 'JPHL' ) company make no warranty of any kind,express or implied,with regards to any information contained in this document.Including,but not limited to, the implied warranties of the accuracy, completeness, merchantability, or non-infringement of third party intellectual property rights.

京鹏沪连公司(以下简称“JPHL”)对本文件包含的所有信息不提供任何明示或默认的担保,包括但不限于关于信息的准确性、完整性、适销性,以及不侵犯第三方知识产权的默认保证。

The Information contained herein is for informational purpose only and is provided only to illustrate the operation of JPHL products described herein and application examples. JPHL does not assume any liability arising out of the application or use of this document or any product described herein.

本文件内容仅作信息参考,仅用于说明文中所述 JPHL 产品的操作方法及应用示例。JPHL 不承担因应用或使用本文件或本文件中描述的任何产品而产生的任何责任。

JPHL reserves the right to make changes to information published in this document, at any time and without notice. This document supersedes and replaces all information supplied prior to the publication hereof.

JPHL 保留随时修改本文件已发布信息权利,且不另行通知,本文件将取代并替换其发布前提供的所有相关信息。

All referenced brands, product names, service names and trademarks are the property of their respective owners.

本文提及的所有品牌、产品名称、服务名称和商标,均归属其各自所有者。



## Contents 目录

1. Mechanical Data 封装数据 .....	1
2. Package Outline Dimensions 封装外形尺寸 .....	2
3. Suggested Pad Layout 推荐焊盘布局 .....	3
4. Minimum Packing Quantity 最小包装数量 .....	3
Important Notice 重要通知 .....	4

---

© JPHL. 2025. All rights reserved

For more information, please visit: [www.jphl-semi.com](http://www.jphl-semi.com)

For business cooperation, please send an email to: [sales@jphl-semi.com](mailto:sales@jphl-semi.com)

Date of release: 26 Dec 2025

©京鹏沪连. 2025. 版权所有

想了解更多信息，请访问 [www.jphl-semi.com](http://www.jphl-semi.com)

商务合作请发送电子邮件至 [sales@jphl-semi.com](mailto:sales@jphl-semi.com)

发布日期：2025-12-26

---